



HADBRO TRANSMISSION PRODUCTS

MISCELLANEOUS APPLICATIONS

MODEL:

GB-9

BEARINGS

I - 25580/25520
 J - LM603049/LM603011
 K L - HM88649/HM88610

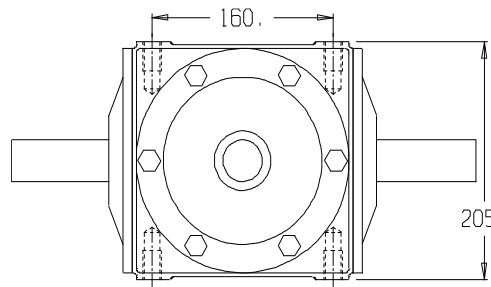
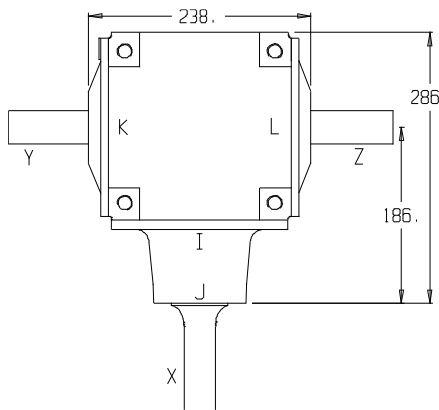

4 MOUNTING HOLES PER SIDE
 M16 x 2.0 PITCH
 25.mm FULL THREAD

SHAFT DETAILS

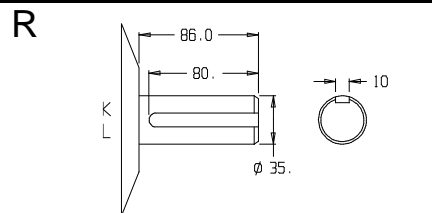
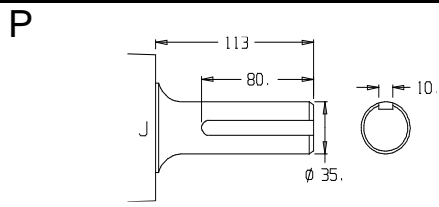
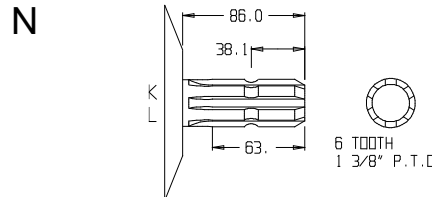
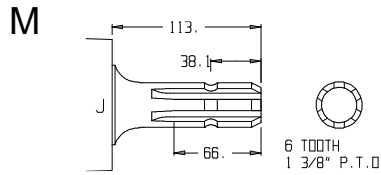

WEIGHT 40 Kg

GEAR LUBRICATION
 Mobilube HD Plus
 80W-90 - 1.5 LITRE

GEARS
 CASE HARDENED
SHAFTS
 HARDENED & GROUND

RATIO	INPUT R.P.M.	INPUT SHAFT	INPUT TYPE	POWER		OUTPUT TORQUE		SHAFTS			GEAR ASSY	CODE No	PRICE EX GST
				H.P.	K.W.	Lb Ins	NM	X	Y	Z			
1:1	540	X	M	98.0	73.0	11438	1292	M	N	N	1 & 2	A9M100N	\$2950.00
			P					M	R	R		A9M100R	\$2950.00
								P	N	N		A9P100N	\$2950.00
								P	R	R		A9P100R	\$2950.00
1:1	540	X	M	98.0	73.0	11438	1292	M	-	N	3 & 4	B9M100N	\$2950.00
			M					-	R	B9M100R		\$2950.00	
			P					-	N	B9P100N		\$2950.00	
			P					-	R	B9P100R		\$2950.00	
1:1	540	X	M	98.0	73.0	11438	1292	M	N	-	5 & 6	C9M100N	\$2950.00
			M					R	-	C9M100R		\$2950.00	
			P					N	-	C9P100N		\$2950.00	
			P					R	-	C9P100R		\$2950.00	
1:1	540	X	M	98.0	73.0	11438	1292	S	S	S	7	D9S100S	\$3300.00
			S					U	U	D9S100U		\$3300.00	
			U					U	U	D9U100U		\$3300.00	
			U					S	S	D9U100S		\$3300.00	
1:1	1000	X	M & P	135.0	100.0	8508	961	As Listed			1 to 7	As Listed	

GEAR ASSEMBLY & SHAFT ROTATION

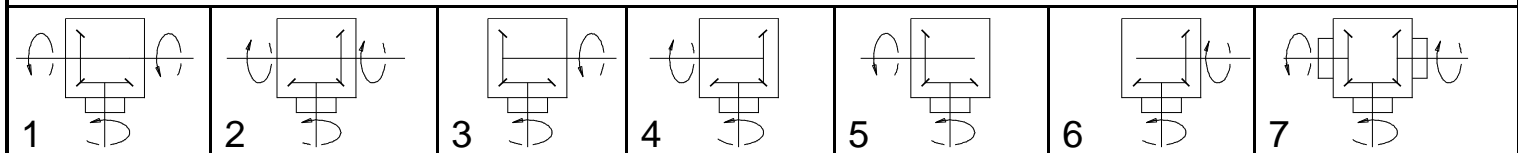



HADBRO TRANSMISSION PRODUCTS

MISCELLANEOUS APPLICATIONS

MODEL:

GB-9

BEARINGS

I - 25580/25520
 J - LM603049/LM603011
 K L - HM88649/HM88610

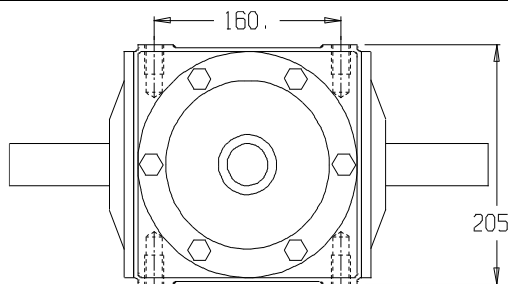
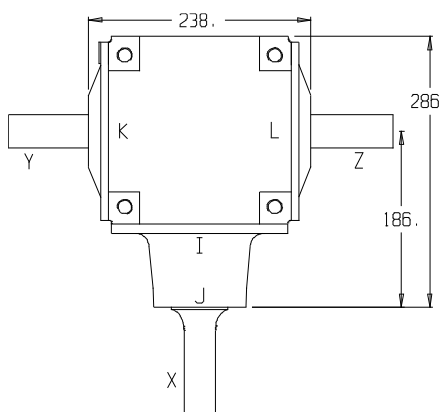

4 MOUNTING HOLES PER SIDE
 M16 x 2.0 PITCH
 25.mm FULL THREAD

SHAFT DETAILS

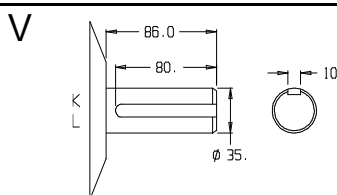
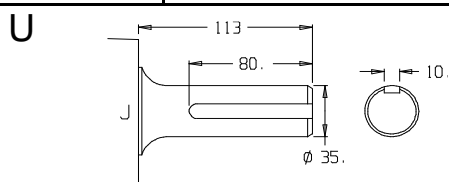
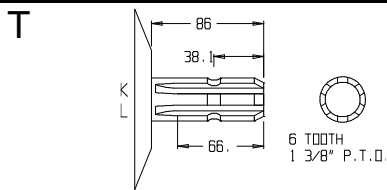
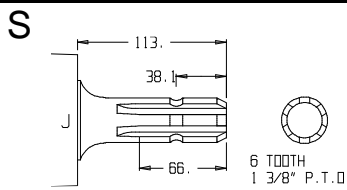

WEIGHT

40 Kg

GEAR LUBRICATION

Mobilube HD Plus
 80W-90 - 1.5 LITRE

GEARS

CASE HARDENED

SHAFTS

HARDENED & GROUND

	RATIO	INPUT R.P.M.	INPUT SHAFT	INPUT TYPE	POWER		OUTPUT TORQUE		SHAFTS			GEAR ASSY	CODE No	PRICE EX GST
					H.P.	K.W.	Lb Ins	NM	X	Y	Z			
SPEED INCREASING UNITS	1:1.3	540	X	S	92.0	68.0	8297	937	S	T	T	1 & 2	A9S130T	\$2950.00
				S					V	V	A9S130V		\$2950.00	
				U					T	T	A9U130T		\$2950.00	
				U					V	V	A9U130V		\$2950.00	
	1:1.3	540	X	S	92.0	68.0	8297	937	S	-	T	3 & 4	B9S130T	\$2950.00
				S					-	V	B9S130V		\$2950.00	
				U					-	T	B9U130T		\$2950.00	
				U					-	V	B9U130V		\$2950.00	
	1:1.3	540	X	S	92.0	68.0	8297	937	S	T	-	5 & 6	C9S130T	\$2950.00
				S					V	-	C9S130V		\$2950.00	
				U					T	-	C9U130T		\$2950.00	
				U					V	-	C9U130V		\$2950.00	
1:1.3	540	X	S & U	92.0	68.0	8297	937	S	S	S	7	D9S130S	\$3300.00	
			U					U	U	D9U130U		\$3300.00		
	1:1.3	1000	X	S & U	115.0	85.0	5600	632	As Listed			1 to 7	As Listed	

GEAR ASSEMBLY & SHAFT ROTATION

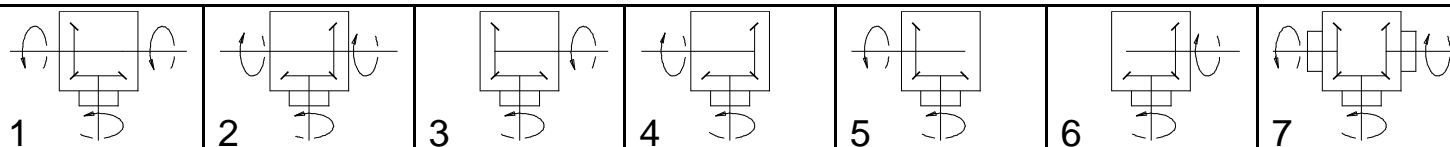



HADBRO TRANSMISSION PRODUCTS

MISCELLANEOUS APPLICATIONS

MODEL:

GB-9

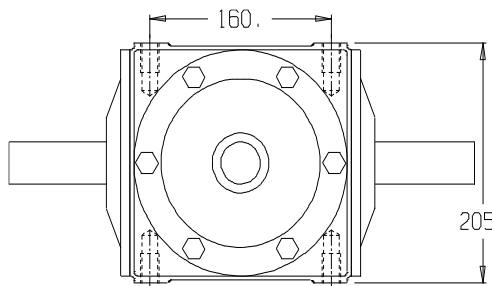
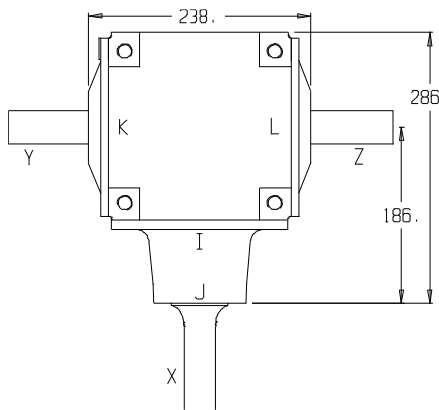

4 MOUNTING HOLES PER SIDE
M16 x 2.0 PITCH
25.mm FULL THREAD

BEARINGS

I - 25580/25520
J - LM603049/LM603011
K L - HM88649/HM88610

SHAFT DETAILS

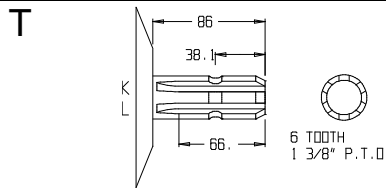
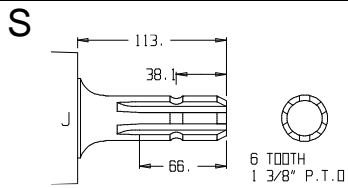

WEIGHT

40 Kg

GEAR LUBRICATION

Mobilube HD Plus
80W-90 - 1.5 LITRE

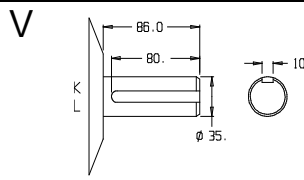
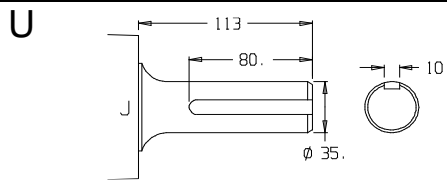

GEARS

CASE HARDENED

SHAFTS

HARDENED & GROUND

	RATIO	INPUT R.P.M.	INPUT SHAF T	INPUT TYPE	POWER		OUTPUT TORQUE		SHAFTS			GEAR ASSY	CODE No	PRICE EX GST
					H.P.	K.W.	Lb Ins	NM	X	Y	Z			
SPEED INCREASING UNITS	1:1.5	540	X	S	89.0	66.0	10387	1173	S	T	T	1 & 2	A9S150T	\$2950.00
				U					S	V	V		A9S150V	\$2950.00
				S					T	T	A9U150T		\$2950.00	
				U					V	V	A9U150V		\$2950.00	
	1:1.5	540	X	S	89.0	66.0	10387	1173	S	-	T	3 & 4	B9S150T	\$2950.00
				U					S	-	V		B9S150V	\$2950.00
				S					-	T	B9U150T		\$2950.00	
				U					-	V	B9U150V		\$2950.00	
	1:1.5	540	X	S	89.0	66.0	10387	1173	S	T	-	5 & 6	C9S150T	\$2950.00
				U					S	V	-		C9S150V	\$2950.00
				S					T	-	C9U150T		\$2950.00	
				U					V	-	C9U150V		\$2950.00	
1:1.5	540	X	S	89.0	66.0	10387	1173	S	S	S	7	D9S150S	\$3300.00	
			U					U	U	D9U150U		\$3300.00		
	1:1.5	1000	X	S & U	110.0	82.0	4621	522	As Listed			1 to 7	As Listed	

GEAR ASSEMBLY & SHAFT ROTATION

