



HADBRO TRANSMISSION PRODUCTS

SLASHER GEARBOX

PAGE 1 of 2

MODEL:

GB-26 CH

BEARINGS

- I – 32016
- J – 33211
- K – 33209
- L – 32016
- M – 32016
- N – 33211

WEIGHT

- T/S & CUTTER HEAD = 109 Kg
- CUTTER HEAD ONLY = 100 Kg

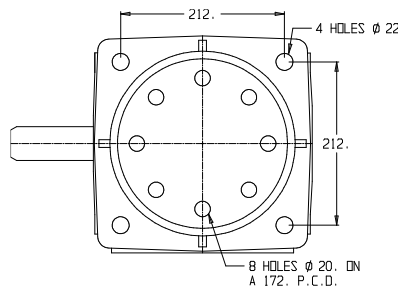
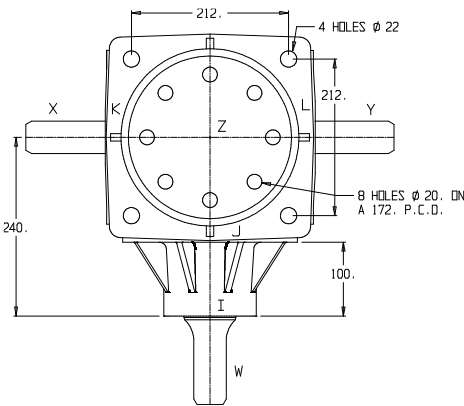
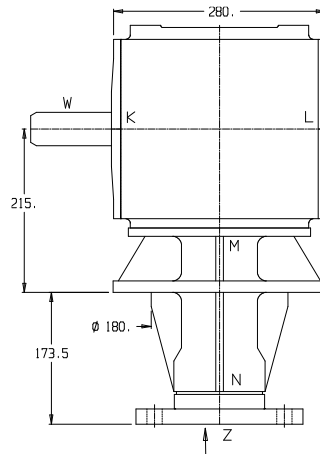
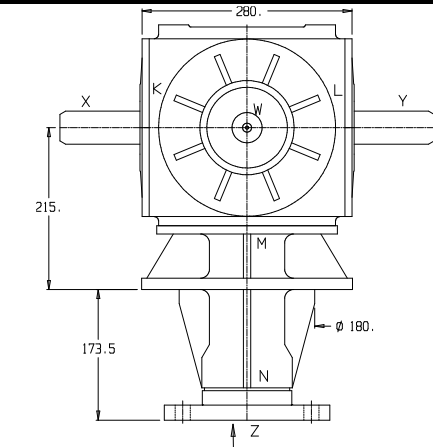

SHAFT DETAILS

R

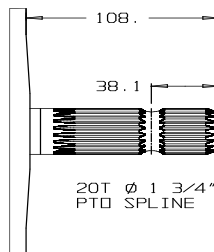

S

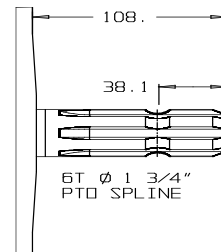

GEAR LUBRICATION

Mobilube HD Plus
85W-140

T

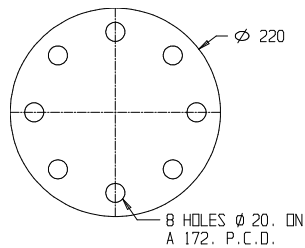

U

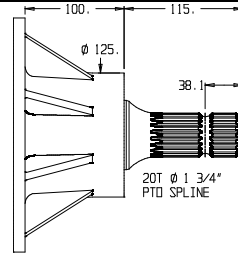

GEARS
CASE HARDENED
SHAFTS
HARDENED & GROUND

RATIO	INPUT R.P.M.	INPUT SHAFT	INPUT TYPE	POWER		OUTPUT TORQUE		SHAFTS				GEAR ASSY	CODE No	PRICES EX GST
				H.P.	K.W.	Lb Ins	NM	W	X	Y	Z			
1:1	540	W	1.75" 20T PTO Spline	190	141	22175	2505	U	-	-	T	4	C26U100T	\$4140.00

GEAR ASSEMBLY & SHAFT ROTATION – LOOKING FROM TOP

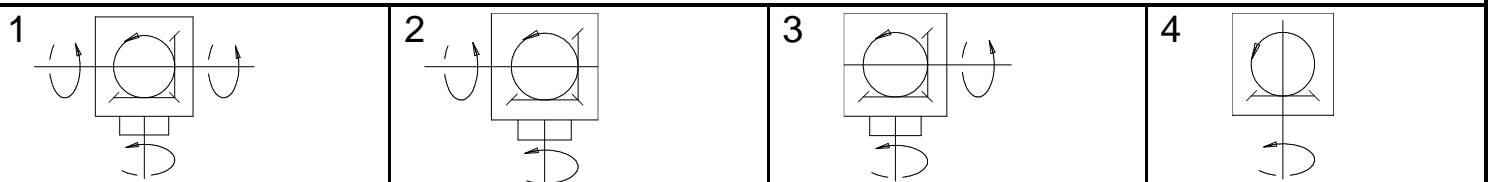



HADBRO TRANSMISSION PRODUCTS

SLASHER GEARBOX

MODEL:

GB-26 CH

RATIO	INPUT R.P.M.	INPUT SHAFT	INPUT TYPE	POWER		OUTPUT TORQUE		SHAFTS				GEAR ASSY	CODE No	PRICE EX GST				
				H.P.	K.W.	Lb Ins	NM	W	X	Y	Z							
SPEED INCREASING UNITS 1:1.53	540	W	1.75" 20T PTO Spline	160	119	12210	1380	U	R	R	T	1	A26U153RT	\$4500.00				
								U	S	S	T		A26U153ST	\$4500.00				
								U	R	-	T	2	B26U153RT	\$4500.00				
								U	S	-	T		B26U153ST	\$4500.00				
								U	-	R	T	3	C26U153RT	\$4500.00				
				U	-	S	T	C26U153ST	\$4500.00									
				160	119	12210	1380	U	-	-	T	4	C26U153T	\$4500.00				
				1:1.88	540	W	1.75" 20T PTO Spline	140	104	8714	984	U	R	R	T	1	A26U188RT	\$4500.00
												U	S	S	T		A26U188ST	\$4500.00
												U	R	-	T	2	B26U188RT	\$4500.00
U	S	-	T									B26U188ST	\$4500.00					
U	-	R	T									3	C26U188RT	\$4500.00				
U	-	S	T					C26U188ST	\$4500.00									
140	104	8714	984					U	-	-	T	4	C26U188T	\$4500.00				

GEAR ASSEMBLY & SHAFT ROTATION- LOOKING FROM TOP

