



# HADBRO TRANSMISSION PRODUCTS

## MISCELLANEOUS APPLICATIONS

MODEL:

### GB-8

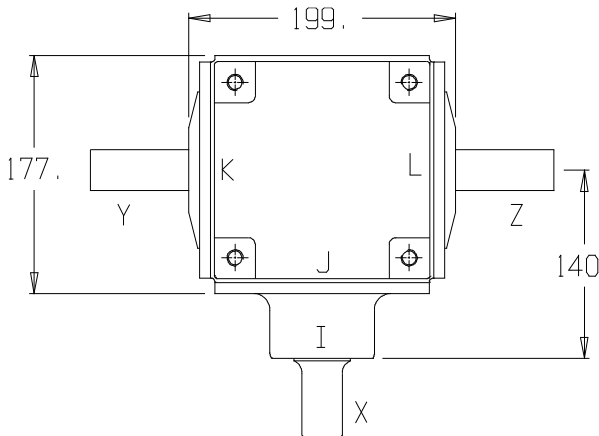

4 MOUNTING HOLES PER SIDE  
M12 x 1.75 PITCH  
20.mm FULL THREAD

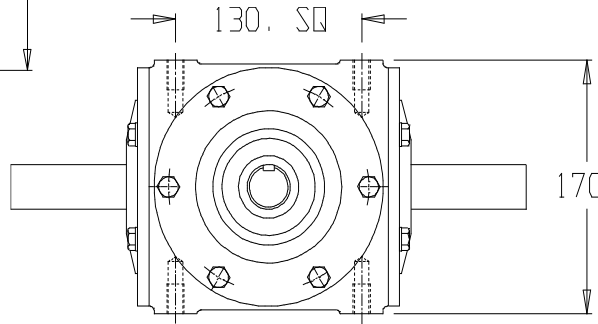

**BEARINGS**

**A & B**

I - 32007

J - 30207

**C & D**

K & L - 30207

**E**

K & L - 30206

**WEIGHT**

23 Kg

**GEAR LUBRICATION**

Mobilube HD Plus

80W-90 - 1 LITRE

**GEARS**

CASE HARDENED

**SHAFTS**

HARDENED & GROUND

**SHAFT DETAILS**

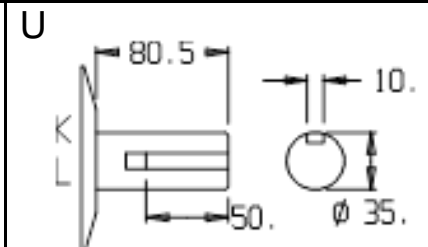
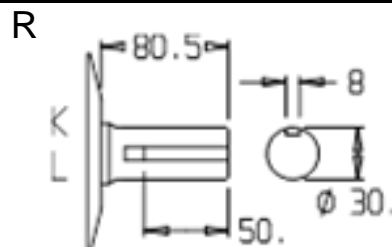
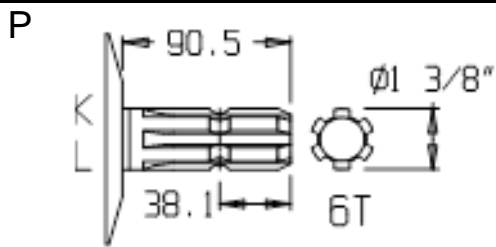
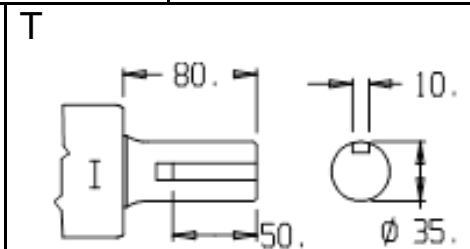
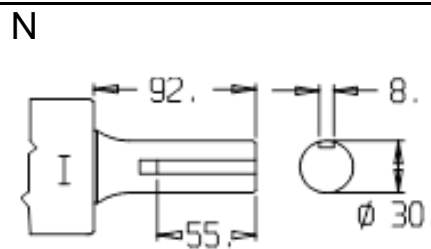
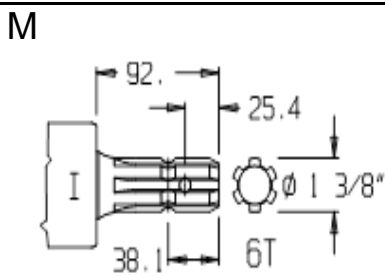

RATIO	INPUT R.P.M.	INPUT SHAFT	INPUT TYPE	POWER		OUTPUT TORQUE		SHAFTS			GEAR ASSY	CODE No	PRICE EX GST
				H.P.	K.W.	Lb Ins	NM	X	Y	Z			
1:1	540	X	M	50.0	37.0	5835	659	M	P	P	1&2	A8M100P	\$1520.00
			M					R	R	A8M100R		\$1520.00	
			M					U	U	A8M100U		\$1520.00	
			N					P	P	A8N100P		\$1520.00	
			N					R	R	A8N100R		\$1520.00	
			N					U	U	A8N100U		\$1520.00	
			T					P	P	A8T100P		\$1520.00	
			T					R	R	A8T100R		\$1520.00	
T	U	U	A8T100U	\$1520.00									

**GEAR ASSEMBLY & SHAFT ROTATION**

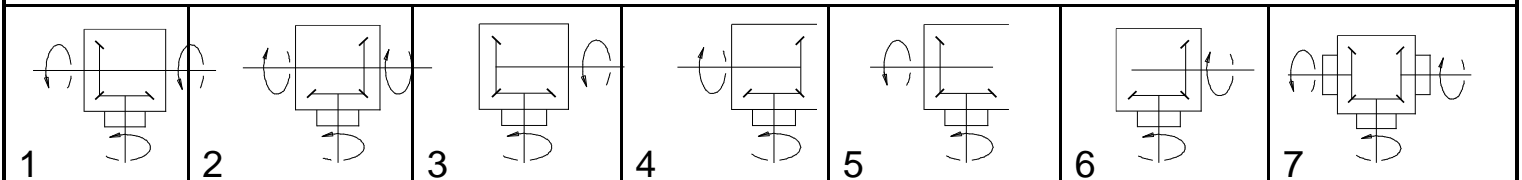



# HADBRO TRANSMISSION PRODUCTS

## MISCELLANEOUS APPLICATIONS

MODEL:

### GB-8

RATIO	INPUT R.P.M.	INPUT SHAF T	INPUT TYPE	POWER		OUTPUT TORQUE		SHAFTS			GEAR ASSY	CODE No	PRICE EX GST
				H.P.	K.W.	Lb Ins	NM	X	Y	Z			
1:1	540	X	M	50.0	37.0	5835	659	M	P	-	3&4	B8M100P	\$1520.00
			M					R	-	B8M100R		\$1520.00	
			M					U	-	B8M100U		\$1520.00	
			N					P	-	B8N100P		\$1520.00	
			N					R	-	B8N100R		\$1520.00	
			N					U	-	B8N100U		\$1520.00	
			T					P	-	B8T100P		\$1520.00	
			T					R	-	B8T100R		\$1520.00	
			T					U	-	B8T100U		\$1520.00	
1:1	540	X	M	50.0	37.0	5835	659	M	-	P	5&6	C8M100P	\$1520.00
			M					-	R	C8M100R		\$1520.00	
			M					-	U	C8M100U		\$1520.00	
			N					-	P	C8N100P		\$1520.00	
			N					-	R	C8N100R		\$1520.00	
			N					-	U	C8N100U		\$1520.00	
			T					-	P	C8T100P		\$1520.00	
			T					-	R	C8T100R		\$1520.00	
			T					-	U	C8T100U		\$1520.00	
1:1	540	X	M	50.0	37.0	5835	659	M	M	M	7	D8M100M	\$1830.00
			M					N	N	D8M100N		\$1830.00	
			N					N	N	D8N100N		\$1830.00	
			N					M	M	D8N100M		\$1830.00	
			T					T	T	D8T100T		\$1830.00	
			R					N	N	D8R100N		\$1830.00	
1:1	1000	X	M,N & T	67.0	50.0	4222	477	As Listed			As Listed		

### GEAR ASSEMBLY & SHAFT ROTATION

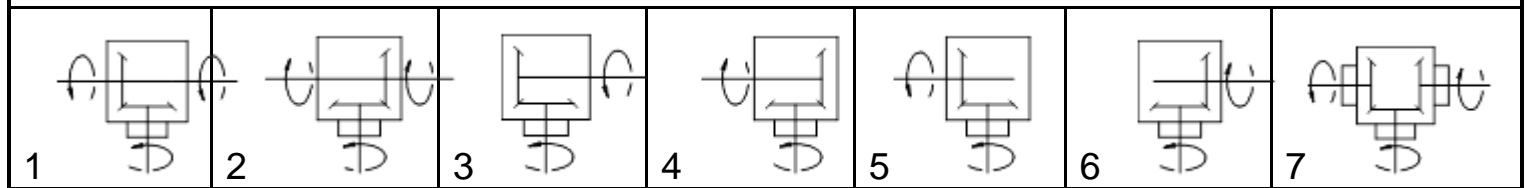

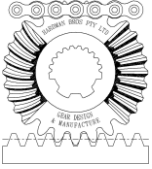

# HADBRO TRANSMISSION PRODUCTS

## MISCELLANEOUS APPLICATIONS

MODEL:

**GB-8**

RATIO	INPUT R.P.M.	INPUT SHAFT	INPUT TYPE	POWER		OUTPUT TORQUE		SHAFTS			GEAR ASSY	CODE No	PRICE EX GST
				H.P.	K.W.	Lb Ins	NM	X	Y	Z			
1:1.47	540	X	M	52.0	39.0	4127	466	M	P	P	1 & 2	A8M147P	\$1520.00
			M					R	R	A8M147R		\$1520.00	
			M					U	U	A8M147U		\$1520.00	
			N					P	P	A8N147P		\$1520.00	
			N					R	R	A8N147R		\$1520.00	
			N					U	U	A8N147U		\$1520.00	
			T					P	P	A8T147P		\$1520.00	
			T					R	R	A8T147R		\$1520.00	
			T					U	U	A8T147U		\$1520.00	
			1:1.47					540	X	M		52.0	39.0
M	R	-		B8M147R	\$1520.00								
M	U	-		B8M147U	\$1520.00								
N	P	-		B8N147P	\$1520.00								
N	R	-		B8N147R	\$1520.00								
N	U	-		B8N147U	\$1520.00								
T	P	-		B8T147P	\$1520.00								
T	R	-		B8T147R	\$1520.00								
T	U	-		B8T147U	\$1520.00								
1:1.47	540	X		M	52.0	39.0	4127			466	M		
			M	-				R	C8M147R		\$1520.00		
			M	-				U	C8M147U		\$1520.00		
			N	-				P	C8N147P		\$1520.00		
			N	-				R	C8N147R		\$1520.00		
			N	-				U	C8N147U		\$1520.00		
			T	-				P	C8T147P		\$1520.00		
			T	-				R	C8T147R		\$1520.00		
			T	-				U	C8T147U		\$1520.00		
			1:1.47	540				X	M		52.0	39.0	4127
M	N	N			D8M147N	\$1830.00							
N	N	N			D8N147N	\$1830.00							
N	M	M			D8N147M	\$1830.00							
T	T	T			D8T147T	\$1830.00							
1:1.47	1000	X	M,N & T	58.0	43.0	2485	280	As Listed			As Listed	As Listed	

GEAR ASSEMBLY & SHAFT ROTATION

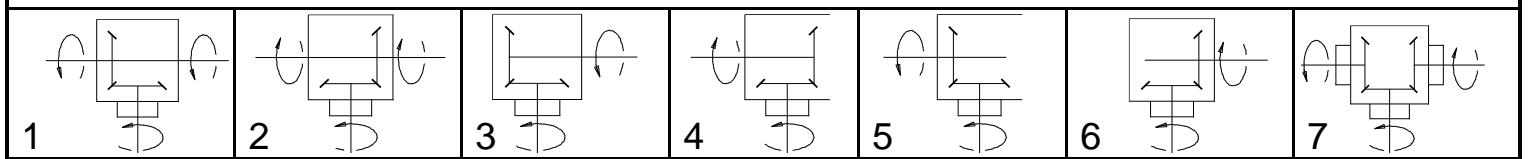



# HADBRO TRANSMISSION PRODUCTS

## MISCELLANEOUS APPLICATIONS

MODEL:

### GB-8

RATIO	INPUT R.P.M.	INPUT SHAFT	INPUT TYPE	POWER		OUTPUT TORQUE		SHAFTS			GEAR ASSY	CODE No	PRICES EX GST
				H.P.	K.W.	Lb Ins	NM	X	Y	Z			
1:0.68	540	X	M	43.0	32.0	7380	834	M	P	P	1 & 2	A8M068P	\$1520.00
			M					R	R	A8M068R		\$1520.00	
			M					U	U	A8M068U		\$1520.00	
			N					P	P	A8N068P		\$1520.00	
			N					R	R	A8N068R		\$1520.00	
			N					U	U	A8N068U		\$1520.00	
			T					P	P	A8T068P		\$1520.00	
			T					R	R	A8T068R		\$1520.00	
			T					U	U	A8T068U		\$1520.00	
1:0.68	540	X	M	43.0	32.0	7380	834	M	P	-	3 & 4	B8M068P	\$1520.00
			M					R	-	B8M068R		\$1520.00	
			M					U	-	B8M068U		\$1520.00	
			N					P	-	B8N068P		\$1520.00	
			N					R	-	B8N068R		\$1520.00	
			N					U	-	B8N068U		\$1520.00	
			T					P	-	B8T068P		\$1520.00	
			T					R	-	B8T068R		\$1520.00	
			T					U	-	B8T068U		\$1520.00	
1:0.68	540	X	M	43.0	32.0	7380	834	M	-	P	5 & 6	C8M068P	\$1520.00
			M					-	R	C8M068R		\$1520.00	
			M					-	U	C8M068U		\$1520.00	
			N					-	P	C8N068P		\$1520.00	
			N					-	R	C8N068R		\$1520.00	
			N					-	U	C8N068U		\$1520.00	
			T					-	P	C8T068P		\$1520.00	
			T					-	R	C8T068R		\$1520.00	
			T					-	U	C8T068U		\$1520.00	
1:0.68	540	X	M	43.0	32.0	7380	834	M	M	M	7	D8M068M	\$1830.00
			M					N	N	D8M068N		\$1830.00	
			N					N	N	D8N068N		\$1830.00	
			N					M	M	D8N068M		\$1830.00	
			T					T	T	D8T068T		\$1830.00	
1:0.68	1000	X	M,N & T	58.0	43.0	5376	607	As Listed			1 to 6	As Listed	

### GEAR ASSEMBLY & SHAFT ROTATION

